

# Harvester Operation and Service Manual

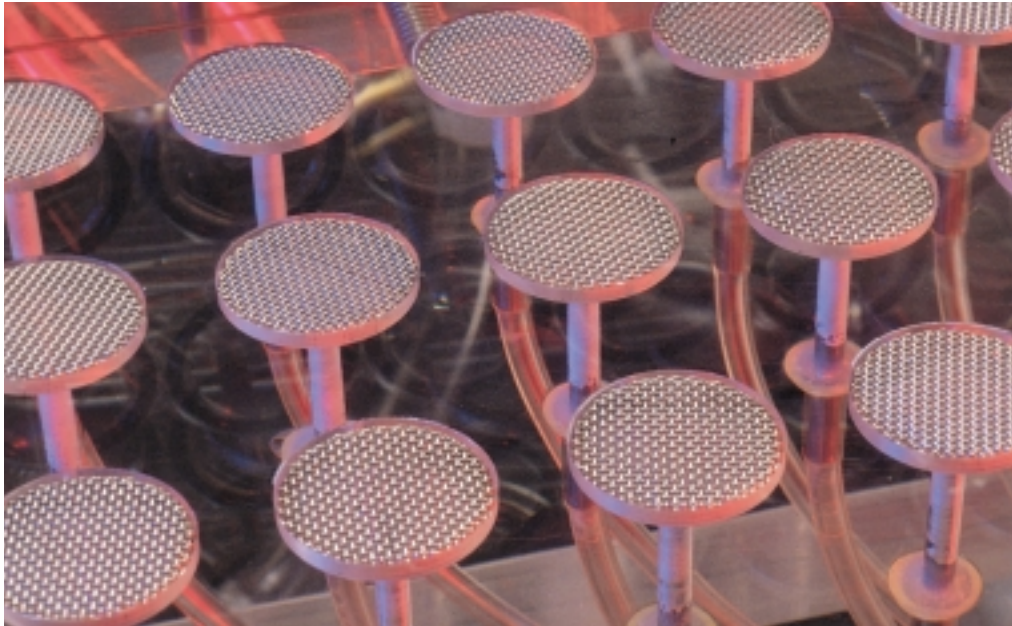

- Before Setting Up Your Harvester* ..... 4
- Parts List* ..... 4
- Requirements* ..... 4
- Harvester Installation* ..... 5
- Wash Installation* ..... 6
- Vacuum Installation* ..... 7
- Operation* ..... 9
- Adjustments* ..... 11
- Interchangeable Harvesting Probe* ..... 17
- Options* ..... 21
- Tubing* ..... 25
- General Maintenance* ..... 26
- Tips for Using Your Harvester* ..... 27
- Filter Paper* ..... 28
- Warranty Information* ..... 29

# Please Read Prior to Operating Harvester

## 1. Using the Harvesting Probe

After completion of harvesting your samples and washing the wells (or tubes) move the on/off valve (see page 7) to the PURGE position for a brief second and then to the OFF position *prior* to opening the filter block. Performing this operation will ensure that there will be no drippage when opening the filter block and that no buffer solution from the harvesting probe will drip onto the filter mat.

## 2. Changing from Filter Mat to Filter Plates: (Models “M\*XRI-96-TI” only)

When changing from filter sheets to filter bottom well plates or vice-versa, the top and bottom inserts inside the filter block must be changed as well. (See page 11 for instructions). Place the filter bottom well plate into the filter block such that “A1” on the plate is towards the back of the Harvester.

If your Harvester only operates with filter bottom well plates and not filter sheets, references in this manual to the o-rings and filter paper should be understood to mean the red gasket on the top half of the filter block and the filter bottom well plate, respectively.

Important

# Thank You

Brandel would like to thank you for your purchase.

Your new Harvester is the product of more than 25 years of ongoing refinement, designed to provide you with many years of use and satisfaction with a minimum of maintenance. We are confident that you will find your Harvester to be one of the best pieces of equipment available today, and for years to come.

If you have any questions or suggestions, now or in the future, please do not hesitate to contact us.

## About this Manual

Copies of this manual are posted on the Brandel web site in Adobe Acrobat® (pdf) format. If you misplace your original or find the digital form more convenient, please feel free to download a copy and save it on your computer for future onscreen reference or printing.

**We strongly encourage you to read this manual carefully as you unpack and assemble your Harvester.** The time you spend doing so will help you to better understand its workings and capabilities, and will minimize the amount of time spent on installation.

Please refer to the General Maintenance section on page 26 for suggestions on keeping your Harvester in optimal condition.

On page 27 you will find Helpful Tips and answers to frequently asked questions.

BRANDEL, Inc.  
8561 Atlas Drive  
Gaithersburg, MD 20877

E-mail: [sales@brandel.com](mailto:sales@brandel.com)  
<http://www.brandel.com>

Telephone: 800-948-6506  
Fax: 301-869-5570

The systems and products displayed in this manual are for illustration purposes only. Due to technical advances, actual products may not be exactly as illustrated.



# Installing Your Harvester

Please Note: The power switch, located on the side of the solenoid box, must be turned on in order for the Harvester to be activated. Brandel strongly suggests that this switch be turned off at the end of each day or harvesting session. Turning this switch off will remove voltage from all components.

In the event of a power surge, or if the power switch is inoperative, replace the fuse (extra 3 amp fuses have been supplied) which is located next to the power switch on the solenoid box.

## 1. Electrical Installation

Connect the male plug from the harvesting probe switch to the matching outlet on the back of the solenoid chassis box.

Plug the female end of the Harvester power cord into the EC 320 connector located on the back of the solenoid, plug the male end of the cord into a standard wall outlet (110V or 220V depending on your region). Depressing the wash switch on the right side of the harvesting probe should cause a clicking sound from the solenoid. Plug the cord from the wash pump into the remaining outlet on the back of the solenoid chassis box.

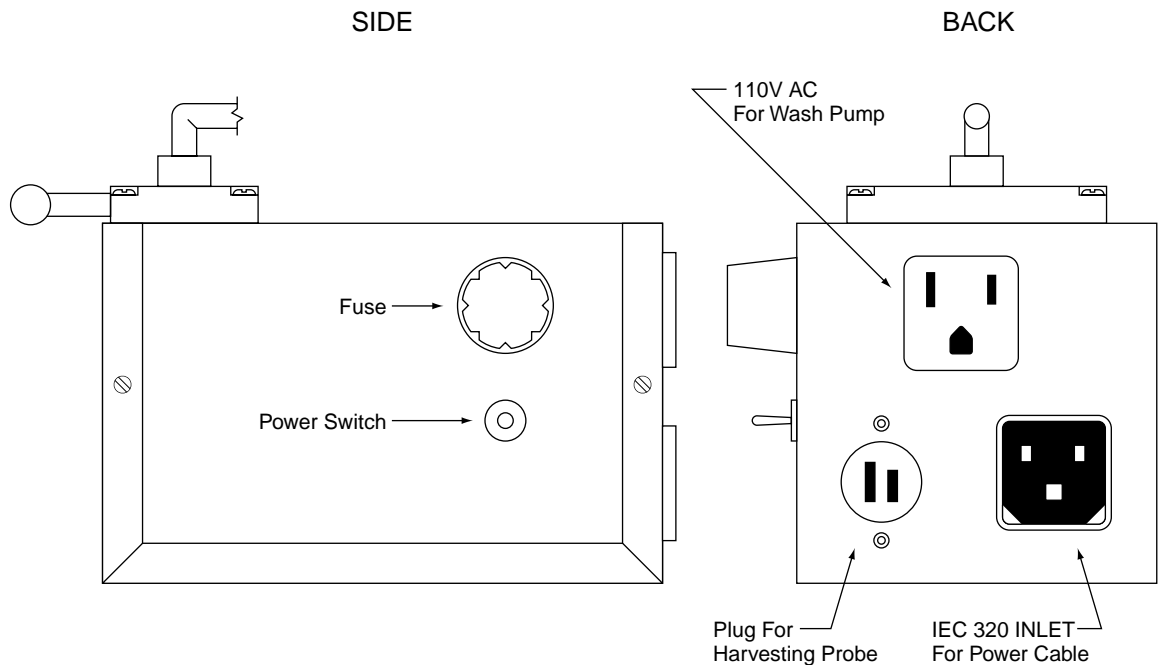



### 3. Vacuum Installation

*This section only applies to machines without the programmable controller.*

The on-off valve, located on the front, right corner of the base plate, eliminates the need for turning on/off your vacuum after each harvesting procedure. Prior to harvesting, the vacuum hose, labeled "connect to on/off valve" on the collection reservoir should have been connected to the open plastic connector of the on-off valve. Turning the handle to the "Harvest" position (Fig. A) will open your vacuum to the Harvester. Turning the handle completely inward to the "Purge" position (Fig. B) will aspirate your buffer solution back towards the wash manifold and prevent any drippage from the harvesting probe when the Harvester is not in use. The "off" position (middle position of valve) will completely shut-down the vacuum to the Harvester and allow for filter paper removal.

#### A. Common Collection of Filtrate

Install the tubing on the collection reservoir (labeled "connect to vacuum source") to a house vacuum line (vacuum source must be equivalent to 20" of 3 Hg. at 3.5 cf./min.) or the vacuum pump. Install the tubing (labeled "connect to on-off valve") to the open 3/8" hose adapter on the on-off valve.

Brandel strongly suggests placing a second collection reservoir in the line going to your vacuum source to prevent water vapor from entering your system.

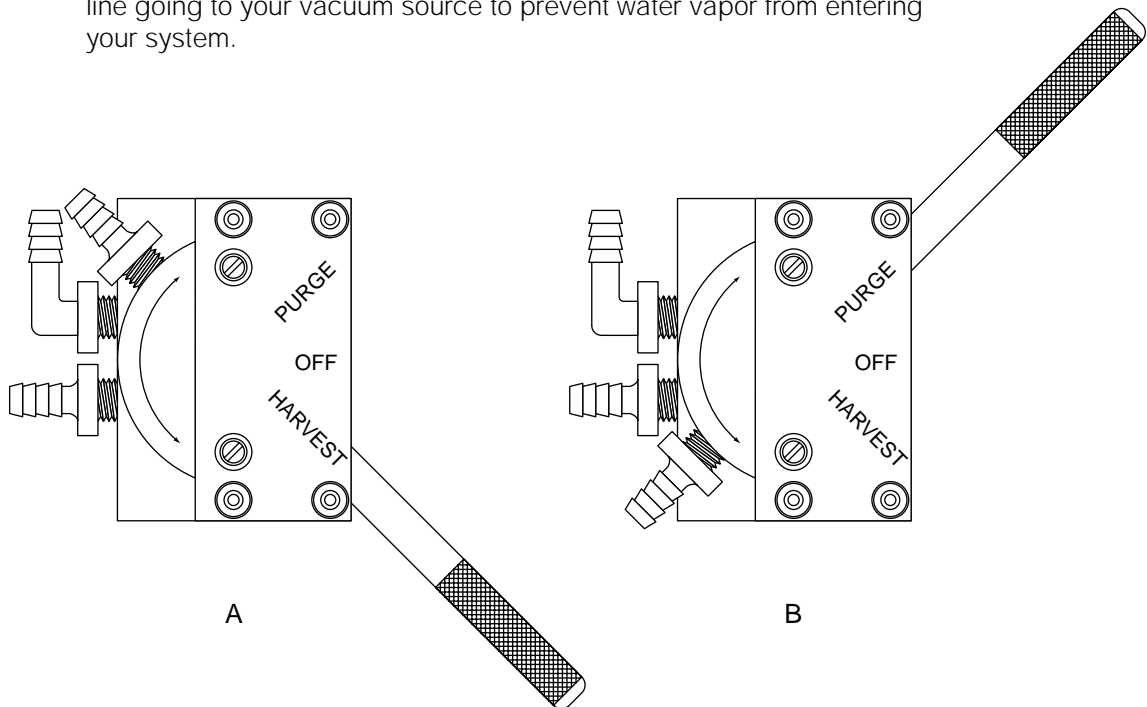

## B. INDIVIDUAL COLLECTION OF FILTRATE

The following six steps must be taken for installation of the individual collection box.

1. Remove the tray on the front of the Harvester to allow for adequate clearance.
2. Open the filter block to ensure that the harvesting probe has been removed

NOTE: If you have the M-96, MB-96 or ML-96 Harvester, the center support bar (directly under the filter block) must be removed prior to steps 3 and 4

3. Remove the 10-14 screws (number of screws depends upon model), see "B" in the figure below, from the underside of the filter block. The common collection manifold will drop down.
4. Remove the vacuum gauge tube from the white fitting (on the manifold) along with the large plastic tubing (connected to the large on/off valve).
5. Ensure that the red gasket on the bottom of the filter block remains in place. From the front of the Harvester, carefully slide the individual collection manifold underneath the bottom of the filter block and re-attach the 10-14 screws removed in step 3.
6. Connect the vacuum gauge tubing to the "tee" connector on the manifold. Connect the large tubing from the individual collection box to the on/off valve.

To remove the individual collection box, reverse the above steps.

When finished collecting your individual filtrates, open the three-way valve (located on the vacuum hose coming from the individual collection box) to release vacuum from the individual collection box.

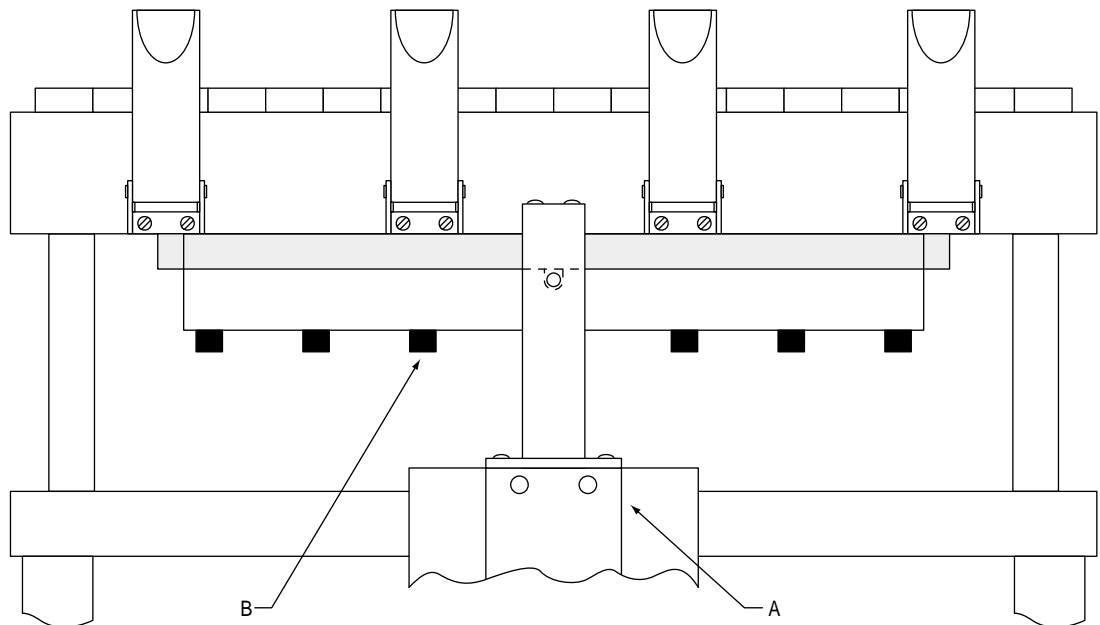

# Operation of Your Harvester

## 1. Microtitre Tray & Test Tube Rack Holder

The tray on the front of the Harvester is for securing your microtitre plate or test tube rack in place while harvesting. The tray and harvesting probe are vertically mobile for the 96-well harvesting probe. When the test tube probe is being used, the tray will be vertically mobile, but the probe will remain fixed.

To raise or lower the tray, place your hands on each of the back-sides of the tray holder. Pushing up or down will adjust the height of the tray.

If the tray is difficult to raise or lower, use the tension adjustment screw which is recessed in the right hand side of the slide housing (see "A" in the figure below). Turn the screw counter-clockwise to reduce the tension and clockwise to increase the tension.

If you are using the 96-well plate, the tray should have a "snug" tension as the probe is movable. When using the test tube probe, the tension should be less snug as the test tube probe is fixed.

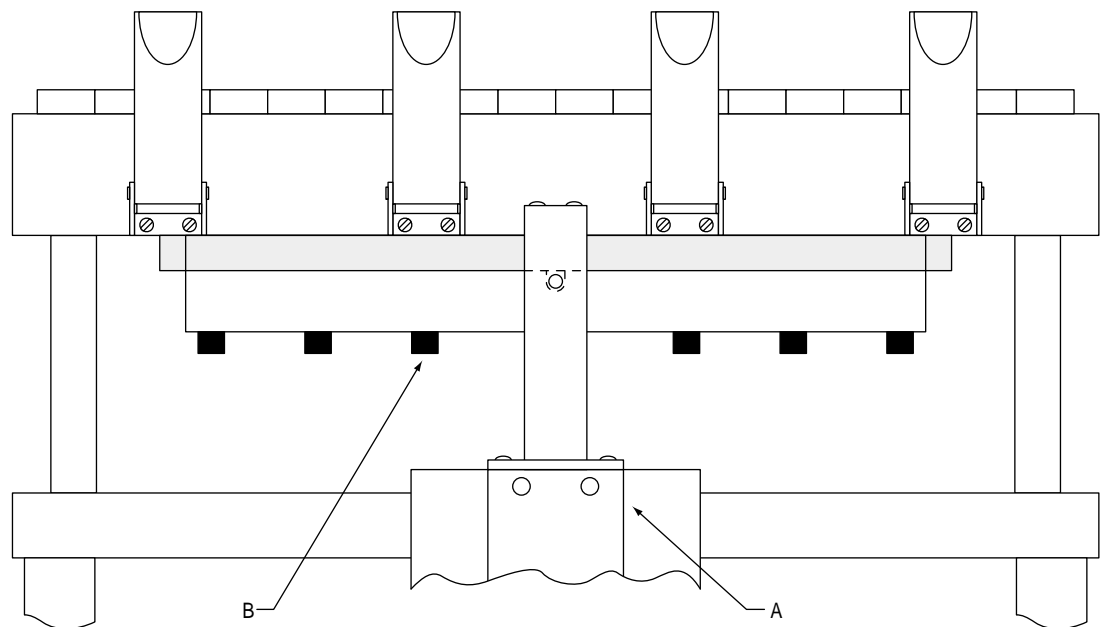

## 2. Proper Aspiration

CAUTION: Release the latches on the front of the filter block when the Harvester is not in use to prevent "flattening" of "o-rings".

Release the four latches on the filter block and raise the top half of the filter block. Place a strip of filter paper over the metal screens on the bottom half of the filter block. The filter paper should be wet to prevent leakage around the edges. Close the filter block, making certain all "o-rings" are completely inside the strip of filter paper. Fasten the four latches to the strikes on the top half of the filter block. Turn on your vacuum source (or open on-off vacuum valve if your vacuum source is already on) and check the vacuum gauge indication to make certain a reading of 18" of Hg. or more is being obtained.

If the vacuum gauge does not read at least 18" of Hg. place the harvesting probe into the microtitre plates or test tubes (depending on type of probe being used) and repeatedly depress wash switch on probe until a reading of 18" of Hg. is obtained.

If a reading of 18" of Hg. is not obtainable make certain that all of the o-rings are "scoring" the paper sufficiently and that all the tubes in the system are secured properly. Please contact BRANDEL if these steps are not sufficient to obtain proper vacuum, as the problem may be a poor quality vacuum source.

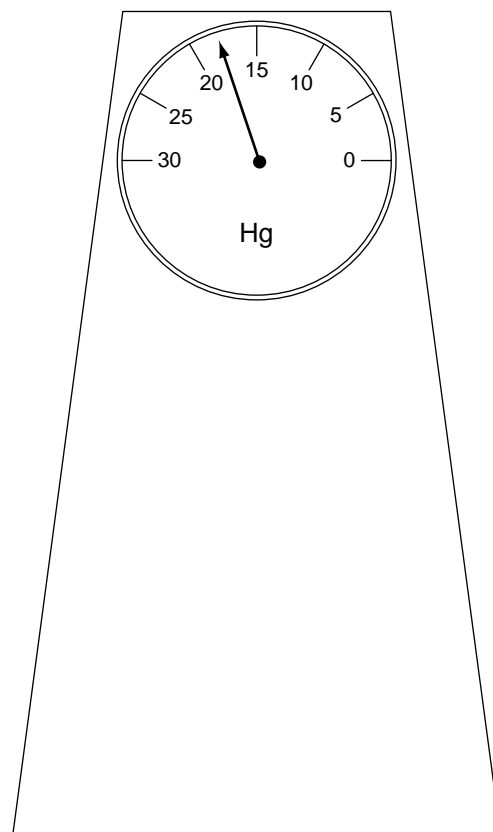

## Making Adjustments to Your Harvester

### 1. Changing the Plate/Mat Inserts

This section only applies to Harvesters with removable Plate/Mat Inserts.

Make certain that the vacuum source has been shut off before changing the plate/mat inserts.

Remove the socket head screws that hold the inserts in place. Care must be taken such as not to remove the large o-ring on the bottom cavity or the smaller o-rings on the top cavity when pulling the inserts out.

Because the new inserts are dowel pinned for easy orientation, they can only properly fit in one way. After placing the new inserts into the cavity, make sure that all o-rings are properly positioned before they are tightened down.

## 2. Proper Delivery

On harvesters working from micro-titre plates, the flow regulator valve between the wash pump and solenoid has been pre-adjusted to prevent an overflow in the wells. Harvesters working from only test tubes have been set for the maximum flow possible. However, if a change in the flow rate is desired, follow the procedure below:

If a decrease in flow is desired (and the harvester is working from test tubes) substitute the additional hose (supplied with flow regulator valve) which was labeled and packed in the accessory box, for the hose which is currently between the wash pump and the solenoid.

Obtain a minimum reading of 18" of Hg. on the harvester vacuum gauge.

Place the harvesting probe in the plate or test tubes and depress the switch.

Adjust the two-way valve such that the flow washes all wells sufficiently and still does not overflow individual wells.

CAUTION: Do not turn the two-way valve so far as to allow only a drizzle of wash fluid to be delivered to any well.

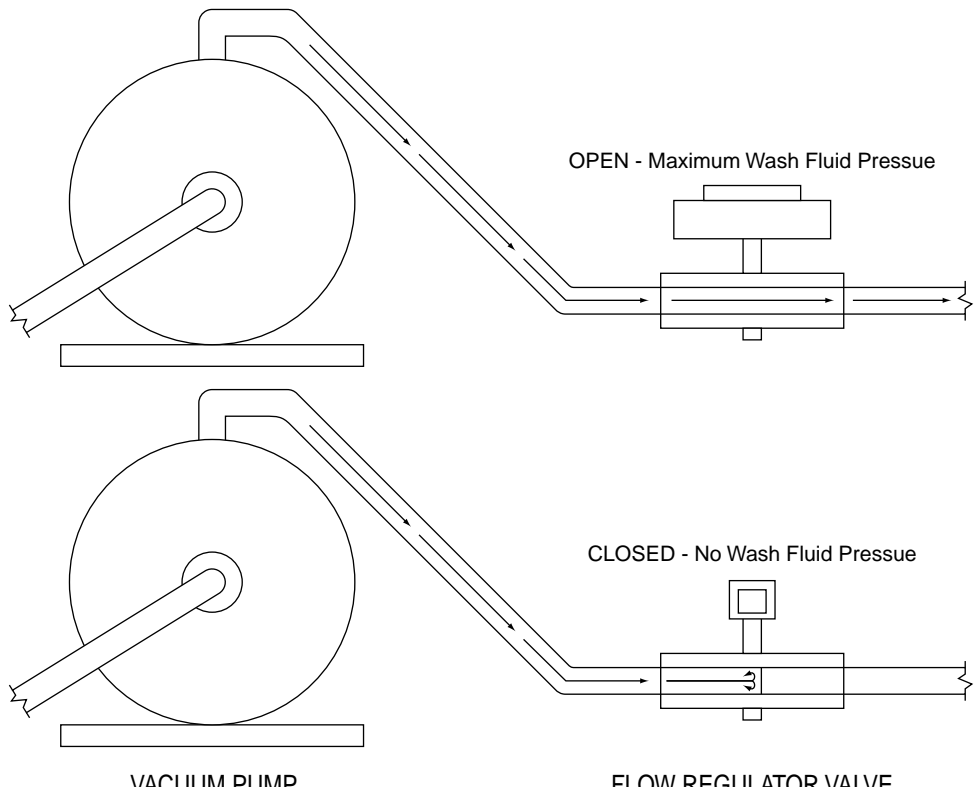

## 2. Individual Flow Adjustment for Each Well

Although this procedure is detailed below, it should never need to be done!  
Please contact BRANDEL before attempting individual flow adjustment!

The flow of each channel has been adjusted such that all channels deliver an equal amount of wash solution. Usually these channels never need to be adjusted. However, if the system requires some further adjustment, adjust the fastest channel such that it delivers the same rate of wash solution as the slowest channel.

When Using the Collection Manifold:

1. Place the probes into individual test tubes or wells. Depress the wash switch on the harvesting probe until the test tubes are approximately 3/4 full.
2. On the flow adjustment bar (secures tubing above harvesting probe) are individual set screws that adjust the flow of each individual delivery needle. To *decrease* the flow, turn the corresponding set screw *in* approximately 1/2 turn, (or less) if a very small change is needed. An allen wrench is supplied.
3. Repeat first step.

When Using The Individual Collection Filtrate Box:

1. Depress the wash switch on the harvesting probe and allow wash media to aspirate until the collection tubes in the collection box are approximately 3/4 full.
2. On the flow adjustment bar (secures tubing above harvesting probe) are individual set screws that adjust the flow of each individual delivery needle. To *decrease* the flow, turn the corresponding set screw *in* approximately 1/2 turn, (or less) if a very small change is needed. An allen wrench is supplied.
3. Repeat first step.

### 3. O-Ring Pressure Adjustment

*Proper scoring is being obtained if all o-rings are making a uniform circular pattern on the filter paper.*

The amount of pressure applied by the "o-rings" was adjusted for proper pressure prior to shipping. However, if a change in the amount of pressure is desired follow the procedure stated on the following page.

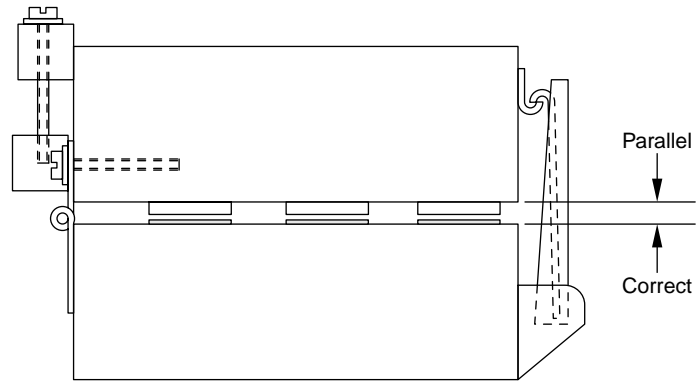

CORRECT

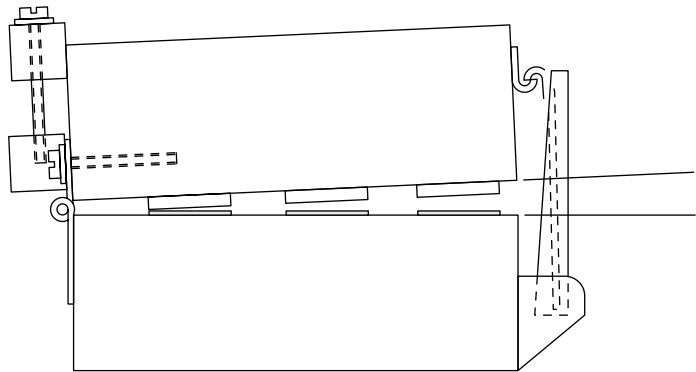

WRONG

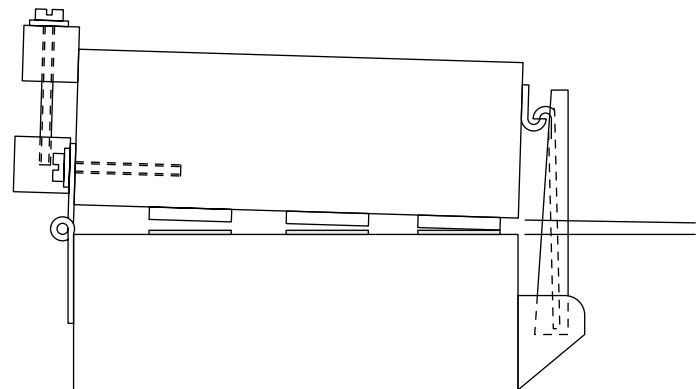

WRONG

### 4. Adjusting Pressure on the Front Half of the Filter Block

Use the latches on the front of filter block. Turning the latches clockwise will increase the amount of pressure applied by the front half of the block. Turning latches counter-clockwise will decrease the pressure applied by the front half of the block.

Only turn latches one turn at a time before re-testing pressure being applied to front half of filter block.

### 5. Adjusting Pressure on the Back Half of the Filter Block

Release the latches on front of filter block and loosen the six screws which are going through the top half of the filter block hinge and into the filter block itself..

There are 3 or 4 sets (depending upon your model of Harvester) of adjustment blocks on the back side of the hinge. Each set of adjustment blocks has one vertical screw inside of it. Turn the vertical screw clockwise to increase the amount of pressure being applied by the back half of the filter block. Turning the screws counter-clockwise will decrease the amount of pressure being applied by the back half of the filter block.

Only turn any screw 1/2 turn before re-testing the pressure being applied to back half of filter block. Prior to re-testing the back pressure of filter block, make certain the six hinge screws have been re-tightened.

### 6. Adjusting Pressure On the Center of the Filter Block: M-96, MB-96 and ML-96 Only

Although detailed below, the following procedure should never need to be performed.

Release the latches on the front of the filter block and tilt top filter block back. The large screw (bolt) coming from the center of the bottom filter block can be used to increase or decrease the pressure applied by the center o-rings. Turning the screw clockwise will increase the pressure, while turning the screw counter clockwise will decrease the pressure applied by the center o-rings.

CAUTION: Do not tighten the screw more than 1/4 of a turn before re-testing. Excessive pressure may damage the bottom filter block!

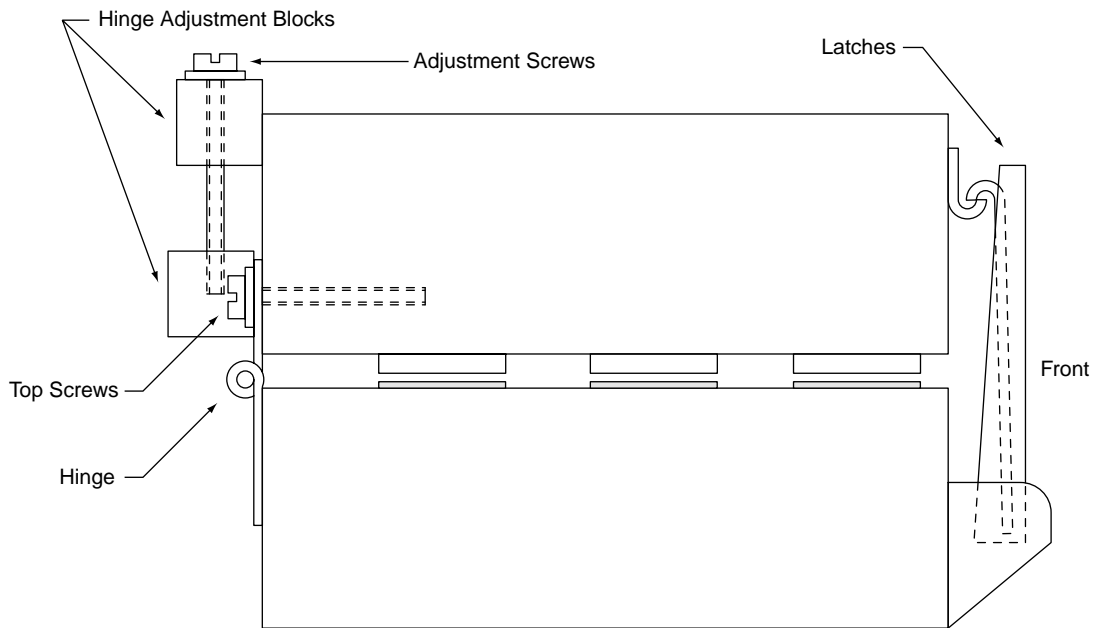

## 7. Realigning the Harvesting Probe

Follow these steps in the order in which they are listed.

### A. LEVELING ADJUSTMENT

The harvesting probe is attached to two metal brackets – one on each side of the probe. If the probe ever needs to be leveled (such that all needles rest flatly against the wells) we have enclosed an allen wrench to assist you. There are six screws, three in each bracket, (see “C” in the figure below) at the sides of the filter block. These can be loosened using the enclosed allen wrench. Close and latch the filter block. Lift the tray holder such that the bottom of the needles rest on the surface of the tray holder. Adjust the probe and tighten the six screws.

### B. PROBE ALIGNMENT

Close and latch the filter block. Lift the tray holder such that the needles fit into the wells. The base of the tray holder has been slotted to allow adjustment of how tightly and where the plate/test tube rack is held in place while harvesting. To adjust the alignment of the plate/test tube probe, loosen the four screws (see “B” in the figure below) on the rectangular aluminum pieces. Slide the pieces in the necessary direction until the proper fit is obtained. Re-tighten all four screws.

CAUTION: Do not over-tighten the screws.

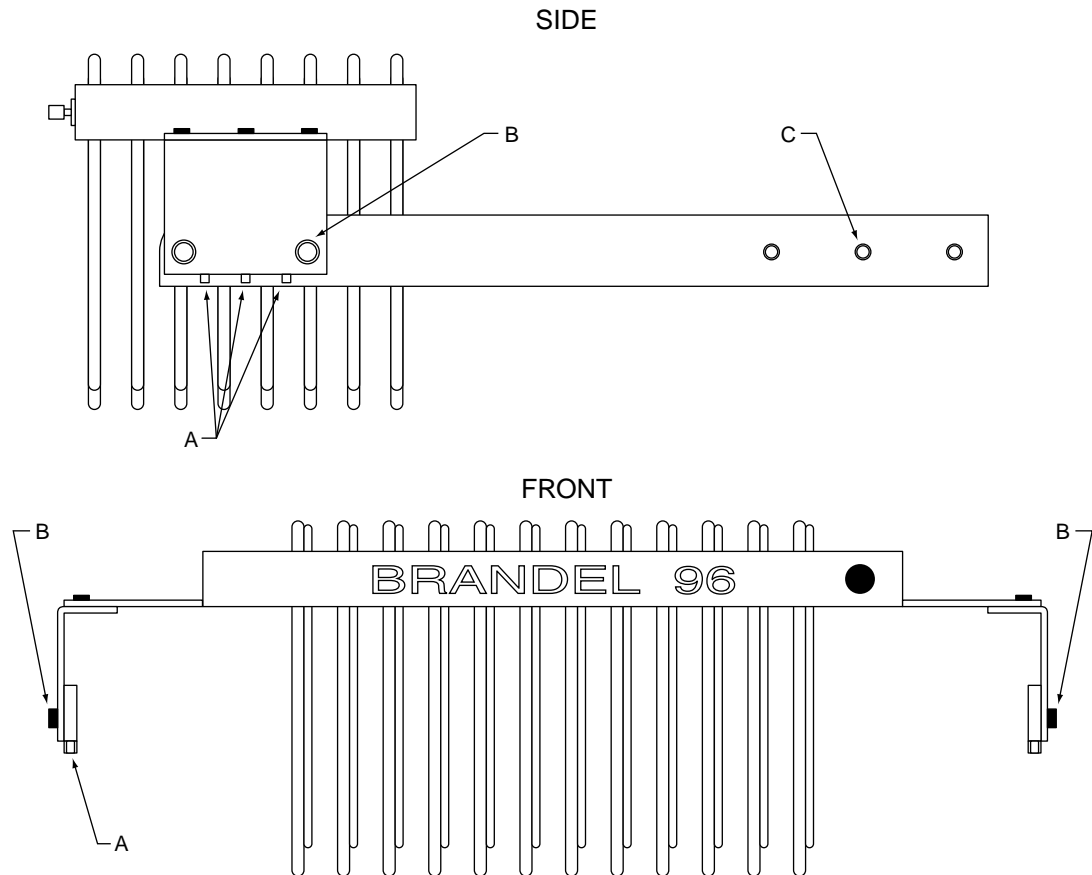

# Interchangeable Harvesting Probe

## 1. Changing Harvesting Probes from 96-Well Plate Probe to Test Tube Probe

### A. Removing the 96-Well Plate

1. Remove all socket screws (6-12) on the top half of the filter block. (See "A" in the figure below)
2. On the extension arms that come off from the left and right side of the Harvester, remove the six socket cap screws. (See "A" in the figure on page 15). These cap screws are located on the bottom, front-most part of the extension arms as you are facing the front of the slide tray,
3. After you have removed the cap screws the two metal plates, (approximately 2" x 4"), will hang loose but will still be attached to the 96-well plate probe.
4. Now the probe can be removed while installation of the test tube probe begins.
5. Installation of the 96-well plate probe can be accomplished by reversing the removal procedure.

NOTE: When installing either probe it is imperative that the delivery manifolds needles, (located on the back, left side of the Harvester), are centered inside the large black o-ring for each manifold. Failure to center these needles will cause fluctuation of your delivery flow rates from one well to another.

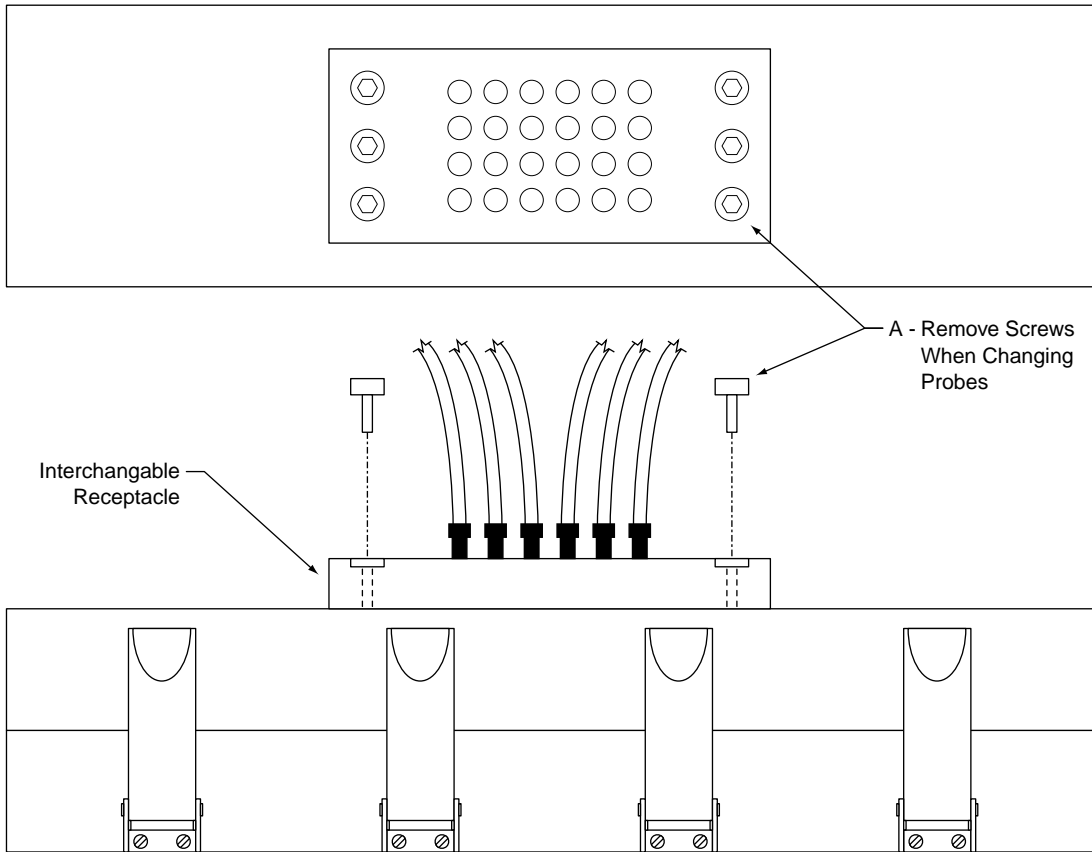

# Optional Components for Your Harvester

## 1. Hot-Cold Collection Valve (manual version; automatic option is available: CH-055)

The hot-cold wash valve is designed to provide the ability for separate collection of radioactive and non-radioactive waste.

If the hot-cold wash valve was not originally ordered with the Harvester and installed by BRANDEL, use the two extra holes located on the left side of the base plate of the Harvester for mounting the hot-cold wash valve.

When using the hot-cold wash valve connect the vinyl tubes on the collection reservoir bottles (labeled "connect to valve") to the two remaining connectors on the bottom half of the hot-cold wash valve. Connect the tube on the plastic "Y" (labeled "connect to vacuum source") to your vacuum source. Connect the two remaining tubes on the plastic "Y" (labeled "connect to trap bottles") to the collection bottles.

When using and disposing of non-radioactive waste turn the top half of the valve (using the handle installed in the valve) in the direction of "cold" port. Turning the valve clockwise (as far as possible) will allow for the use and disposal of radioactive waste into the "hot" collection reservoir bottle.

To disassemble the hot-cold wash valve remove the two screws located on the bottom side of the base plate which are securing the valve. Remove the four caphead screws on the top half of the valve cover, counter-clockwise, thus removing the white colored valve housing on the top of the valve. Remove the large cap screw inside the top half of the valve such that both pieces will come apart. Use your fingers to remove the o-rings. *Do not* use a sharp instrument to remove the o-rings.

To assemble, reverse the above process. When tightening the cap screw make certain that the o-rings are sealing against the bottom of the top half of the valve. Check the turning motion for ease of movement.

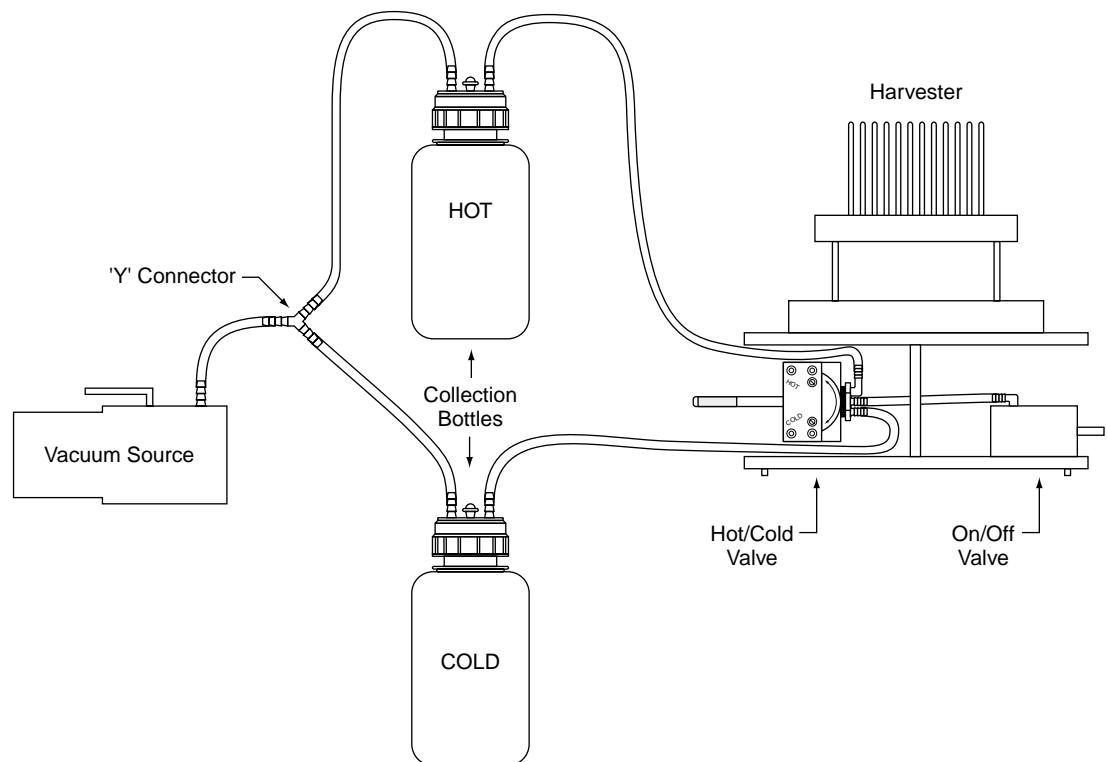

Options

## 2. Wash Timer (manual version; automatic option is available: CH-055)

The wash timer assures that the same volume of wash solution is delivered to your wells each time.

### A. Installation

Place the wash timer next to the Harvester in a convenient location.

Remove the male plug from the end of the cord that is marked "TO SWITCH." When using the wash timer, place this male plug into the back of the solenoid box on the back of the Harvester. This will allow the timer to effectively operate the Harvester.

Plug the female plug marked "TO SWITCH" into the male plug coming from the probe cord of the Harvester.

Plug the power cord of the Harvester into the back of the wash timer plug marked "TO HARVESTER."

Plug the power cord of the timer marked "TO 110VAC" into a standard wall outlet (110V or 220V depending on your region).

### B. Operation

Manual mode allows the operator to determine the amount of delivered wash solution each time. The timer does not need to be disconnected from the Harvester for manual operation.

Automatic mode allows delivery of an identical amount of wash solution to all wells each time.

In Automatic mode, the delivery amount can be adjusted by turning the knob on top of the wash timer.

To engage the wash timer, position the harvesting probe into the wells and hold down the switch on the probe. Wash delivery will automatically discontinue at the time interval selected.

If the delivery switch is released prior the end of the desired time cycle, delivery will discontinue immediately and the timer will reset itself.

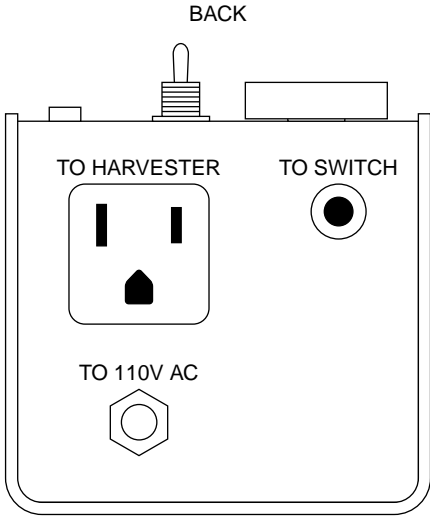
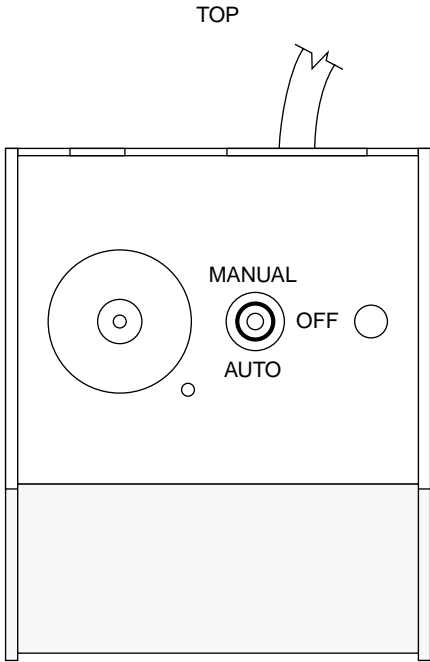

110V WASH TIMER

## C.. Delivery Time

The timer has an almost infinite amount of settings, which will allow for a greater time period than the Harvester would ever need. For the purposes of this manual we only consider the reasonable settings (amount of time) that could be used with the Harvester.

Upon shipping, the timer was set to run from 1-10 seconds and can be adjusted to the preferred setting by turning the dial. However, if a period of time longer than ten seconds is desired, please refer to the table shown below to obtain the proper setting.

*Turning the left screw adjusts the Time Selector:* this adjustment gives you four choices that begin with times of: 0.5 or 1.0 or 2.0 or 10.0

*Turning the right screw adjusts the Time Unit Display:* this adjustment gives you a choice of either seconds or minutes

When the time selector is adjusted to show the numbers in the far left column and the dial is set at the number on the second column from the left, and the time unit display is set to seconds, the amount of time (in seconds) the timer will operate is shown in the third column from the left.

When the time selector is adjusted to show the numbers in the far left column, and the dial is set at the number on the second column from the left, and the time unit display is set to minutes, the amount of time (in seconds) the timer will operate is shown in the far right column.

### TIMER FACE

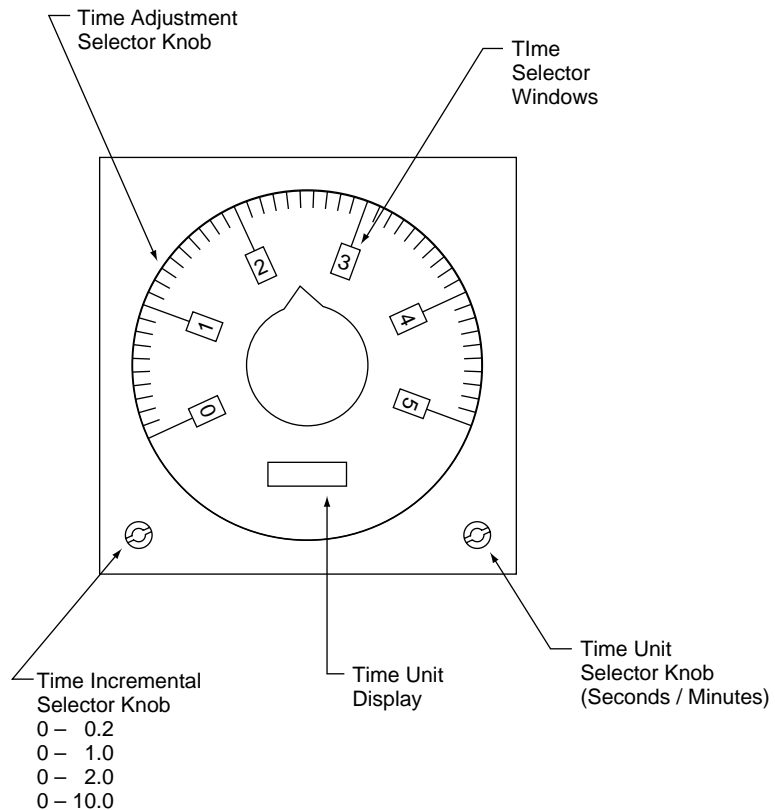

### 3. Multi-Wash Systems

(for additional washes)

A complete wash system (if ordered) consists of:

- 1 each Wash Pump (optional)
- 1 each Wash Media Bottle
- 1 each Multi-Wash Table with Switch
- 1 each Wash Trough (mounted onto multi-wash table)
- 1 each Solenoid (mounted onto multi-wash table)
- 1 each 2-Way Flow Regulator Valve
- 1 each Necessary Tubing

Only part of the system may have been ordered with your Harvester. All instructions should be modified accordingly.

#### A. Connections and Installation

1. Connect the tubing from the multi-wash buffer bottle, labeled "connect to multi-wash pump," to the wash pump.
2. Connect the tubing labeled "connect to multi-wash solenoid" to the white fitting of the solenoid on the multi-wash table.
3. Prime the multi-wash pump in the same manner as priming the wash pump for the harvester (see page 5).
4. Place the multi-wash table over the harvester tray in such a manner that the wash trough is directly underneath the 96 probe.
5. The flow regulator valve has already been pre-set. If a change in flow is desired turn the handle on the flow regulator valve. (Turning the handle parallel to the valve increases the flow, turning the handle perpendicular decreases the flow).
6. Plug the multi-wash pump plug into the back of the multi-wash solenoid.
7. Plug the multi-wash switch (located on the multi-wash table) into the back of the multi-wash solenoid.
8. Plug the multi-wash solenoid into a standard wall outlet (110V or 220V depending on your region).
9. Raise the harvester tray and begin use by depressing the multi-wash switch.

The wash is fed into the trough by the depression of its corresponding switch located on the multi-wash table. (If a wash pump was purchased with the multi-wash system, the two-way valve on the tubing from the wash pump can be adjusted to regulate the rate of flow into the wash trough). With vacuum pressure applied and after filling the wash trough, place the harvesting probe into the wash trough. The harvesting probe will aspirate the additional wash fluid from the trough onto the filter paper. Additional washings may be accomplished by repeating this procedure.

# Tubing for 96-Sample Harvesters

Interchangeable Receptacle

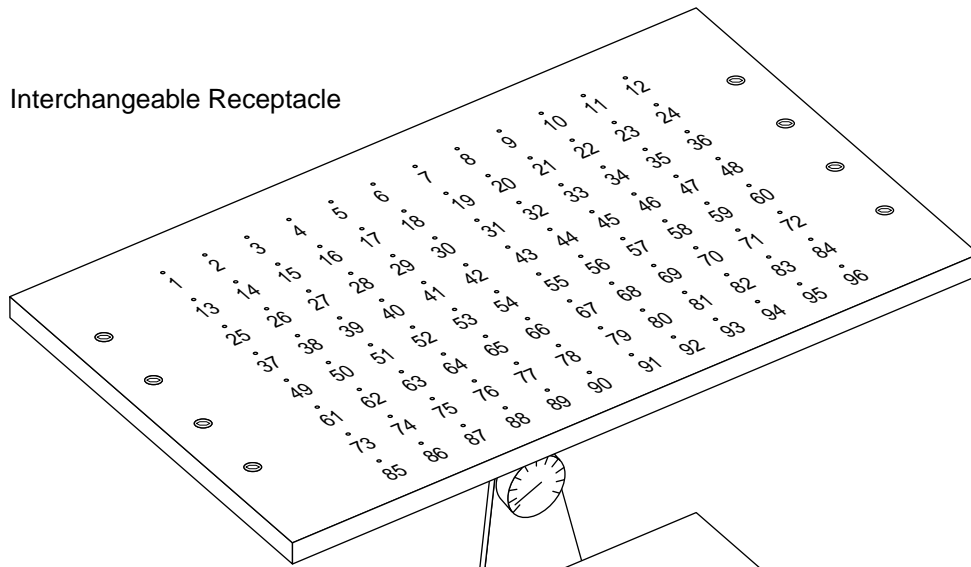

Filter Block

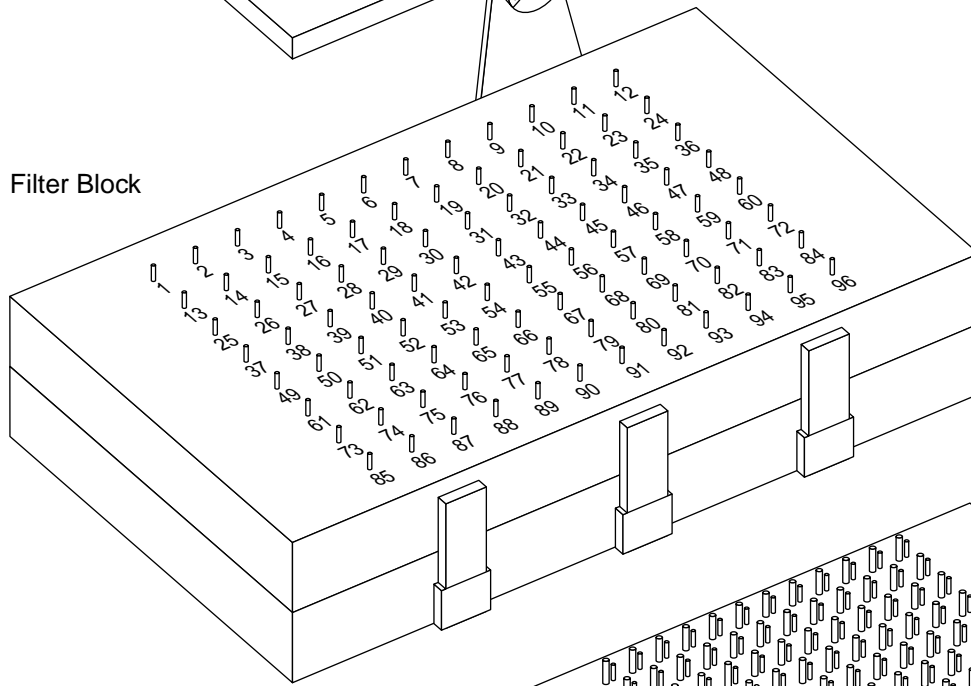

Tubing Assignments for Probe

1	2	3	4	5	6	7	8	9	10	11	12
13	14	15	16	17	18	19	20	21	22	23	24
25	26	27	28	29	30	31	32	33	34	35	36
37	38	39	40	41	42	43	44	45	46	47	48
49	50	51	52	53	54	55	56	57	58	59	60
61	62	63	64	65	66	67	68	69	70	71	72
73	74	75	76	77	78	79	80	81	82	83	84
85	86	87	88	89	90	91	92	93	94	95	96

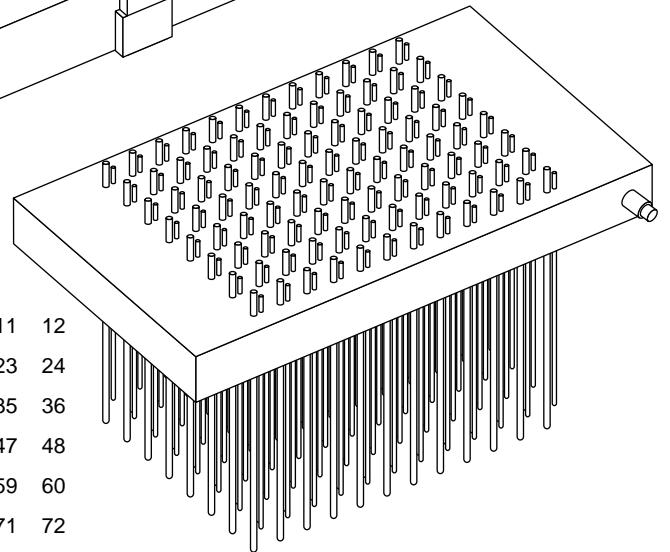

Tubing

## General Maintenance

Your BRANDEL Harvester has been designed for relatively maintenance free service. However, certain steps should be taken to provide optimal service from your Harvester. The steps detailed below will not only keep your Harvester aesthetically clean, but also provide for uniform delivery and aspiration – even after years of use.

After shipment, and/or continued use of the Harvester the white plastic permanent ties binding together the clear plastic tubing may need to be tightened. *However, caution should be exercised so as not to pinch shut any tubes.* Normally, pushing down on the square part (head) of the plastic permanent tie for one or two notches is sufficient to secure the tubes into a firmly held bundle.

All outside lucite parts can be cleaned with alcohol, Windex or any other cleaning agent of your choice which is not abrasive or a solvent to lucite.

After a few hours of occasional use or continued use over the course of a day the tubing should be rinsed out with deionized water or a solution of 30% alcohol. After a period of time a chemical solution can also be used to prevent or eliminate any counts from remaining inside the tubing.

A soft bristled brush (such as a toothbrush) may be used with water or alcohol to clean the stainless steel filter screens.

After prolonged use over years you may wish BRANDEL to provide replacement tubing, o-rings or screens.

BRANDEL can provide tubing in coils (you re-tube the lines to be changed) or all tubes coming to and going from harvesting probe pre-cut with a new wash manifold (for your convenience), labeled and ready to be installed. This tubing can also be pre-cut for your collection manifold (new collection manifold, for your convenience), labeled and ready to be installed.

All o-rings are supplied with epoxy for replacement.

Your Harvester's stainless steel filter screens have been pressed into your filter block. BRANDEL will supply the replacement screens for you to fit back into place. Simply remove the old screen; pry out with a suitable object, and place the new screens into place.

# Tips for Using Your Harvester

## 1. Proper Aspiration

Make certain that the aspiration needles in the harvesting probe are not sitting on the bottom of the wells when aspirating. Hold the probe slightly above the bottom of the wells in order to prevent the bottom of the aspiration needles from sealing against the bottom of the wells. If the aspiration needles of the harvesting probe are sealing against the bottom of the wells, certain wells may overflow.

Make certain that with a strip of filter paper inside the filtering block your vacuum gauge is reading a minimum of 18" Hg. while aspirating. A vacuum reading of less than 18" Hg. may lead to poor aspiration, and individual wells overflowing.

While not using the Harvester, the filter block should be closed but *not latched*, to prevent unnecessary strain on the o-rings.

Make certain that if you are using a microtitre plate configuration you have adjusted the two way valve on the black wash pump to prevent an excessive amount of delivery into each individual well.

Make certain that the handle on the on-off vacuum valve is fully turned to the "HARVEST" position in order to ensure proper aspiration from the harvesting probe.

If you are using the tray on the front of the Harvester, and are harvesting (especially from test tubes), make certain that while the harvesting probe is held off the bottom of the wells that the tubing is not being crimped on the back side of the harvesting probe. Holding the probe near the latches on the filter block (in other words, at the back edge of the tray) *and* very high off the bottom of the wells (5" or more) *may* cause a decrease in the aspiration.

## 2. Proper Delivery

Make certain that the handle on the on-off vacuum valve is fully turned to the "HARVEST" position and secured in place to allow for delivery to the harvesting probe. If the handle is *not* fully turned to the "HARVEST" position, the buffer solution will go directly into your collection flask.

Make certain that the wash pump has been completely primed.

Make certain that if you are using a two-way valve on the black wash pump not to have the valve closed so far as to prevent an adequate amount of delivery into each individual well.

## 3. After Harvesting

Prior to placing the two metal rods of the harvesting probe into the corresponding holes on the top half of the filter block, pull back on the tygon tubing which is above the filter block. Pulling this tubing toward the back of the Harvester will allow the harvesting probe rests (two metal rods) to fit better and remain seated into the filter block.

# Filter Paper for All Harvesters

Harvester	Reeves Angel 934H	Whatman GF/B	Whatman GF/C
For Standard Format Harvesters <i>without</i> Deposit/Dispensing Systems			
12-sample Harvesters	FP-12	FP-101	FP-201
24-sample Harvesters	FP-24	FP-100	FP-200
30-sample Harvesters	FP-30	FP-130	FP-230
36-sample Harvesters	FP-36	FP-136	FP-236
48-sample Harvesters	FP-48	FP-105	FP-205
96-sample Harvesters	FPD-96	FPD-196	FPD-296
For Standard Format Harvesters <i>with</i> Deposit/Dispensing Systems			
12-sample Harvesters	FPD-12	FPD-101	FPD-201
24-sample Harvesters	FPD-24	FPD-100	FPD-200
30-sample Harvesters	FPD-30	FPD-130	FPD-230
36-sample Harvesters	FPD-36	FPD-136	FPD-236
48-sample Harvesters	FPD-48	FPD-105	FPD-205
96-sample Harvesters	FPD-96	FPD-19	FPD-296
For All Counter-Compatible Harvesters			
12-sample, 20ml vials	FP*-12	FP*-112	FP*-212
18-sample, 5 or 7ml vials	FP*-18	FP*-118	FP*-218
24-sample, 20ml vials	FP*-24	FP*-124	FP*-224
30-sample, 20ml vials	FP*-30	FP*-130	FP*-230
36-sample, 5 or 7ml vials	FP*-36	FP*-136	FP*-236
36-sample, 20ml vials	FP*-36L	FP*-136L	FP*-236
48-sample, 5 or 7ml vials	FP*-48	FP*-148	FP*-248
48-sample, 20ml vials	FP*-48L	FP*-148L	FP*-248L
96-sample, 5 or 7ml vials	FP*-96	FP*-196	FP*-296
96-sample, 20ml vials	FP*-96L	FP*-196L	FP*-296L
For All Direct Radioactive Reader Compatibles			
24-sample 4x6 format	FP*R-24	FP*R-124	FP*R-224
48-sample 4x12 format	FP*R-05	FP*R-105	FP*R-205
96-sample 6x16 format	FP*R-96	FP*R-196	FP*R-296
96-sample microtitre	FPX*R-96	FPX*R-196	FPX*R-29

\* Please enter the letter that corresponds to your counter or direct reader: **B** Beckman **L** LKB **P** Packard  
Others filters available on request

BRANDEL, Inc.  
8561 Atlas Drive  
Gaithersburg, MD 20850  
Telephone: 301-948-6506  
Fax: 301-869-5570  
E-mail: sales@brandel.com  
<http://www.brandel.com>

Filter Paper

## Warranty

Biomedical Research and Development Laboratory, Inc. (BRANDEL) guarantees for a period of one year from the original date of shipment, all parts manufactured by it to be free from defects in workmanship and materials. All defective parts will be replaced without charge for parts or labor. BRANDEL will not accept expense or labor incident to the replacement of any part outside of its factory.

## Warning

The purchaser assumes all risks in the use and handling of items sold by BRANDEL. BRANDEL is not liable for loss or damage resulting from use or misuse of the products sold by BRANDEL.